



A661

2 x 24-Port Rugged Managed Ethernet Switch



- Managed Gigabit Ethernet Switch
- Rugged Cold Plate Cooled Enclosure
- Layer 2 and Layer 3 Management
- 2 x 24 1000Base-T Ports
- Full Wire-speed Non-blocking Forwarding
- IP Routing Functionality
- Advanced Spanning Tree Algorithms (RSTP, MSTP)
- Access Control List (ACL) Support
- QoS Management
- IPv4/v6 Differentiated Services (DiffServ)/DSCP Traffic Prioritization
- WEB and CLI Configuration and Monitoring
- 802.1Q-based VLAN Support
- Port-level Security via 802.1X Authentication
- SNMP v1, v2c, v3
- Supports OSPF v3, PIM
- 4/8/16 Group LAG Support with Protocol (LACP)
- All types of Storm Control
- Port Mirroring for Noninvasive Monitoring of Switch Traffic
- Jumbo Frame Support (10 kB)
- Integral Rugged Power Supply
- Temperature Sensors

Aitech Defense Systems, Inc.

A member of the Aitech Rugged Group

19756 Prairie Street, Chatsworth, CA 91311

Tel: (888) Aitech-8 (248-3248) Fax: (818) 407-1502 e-mail: sales@rugged.com web: www.rugged.com

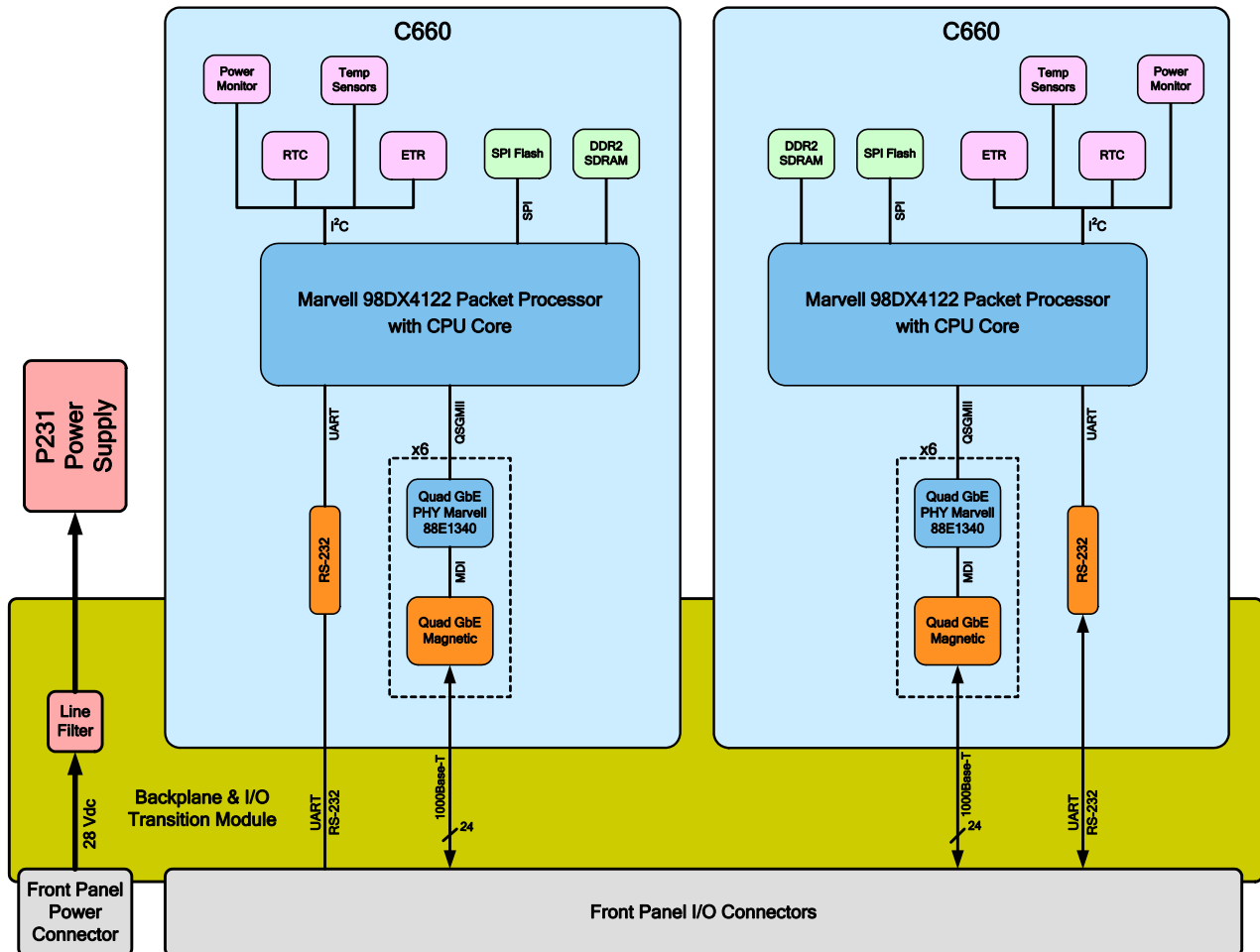

A661 Functional Block Diagram

Functional Description

System Architecture

Aitech's A661 is a rugged 48-port (2 x 24 ports) managed Gigabit Ethernet switch comprising two Aitech C660 24-port Ethernet Switch boards housed in a rugged enclosure. The C660 boards are based on the Marvell Prestera 98DX4122 Multi-Layer Gigabit Ethernet Switch packet processor, which performs Layer 2 and Layer 3 routing and switching for the 24 Gigabit Ethernet ports.

An integrated high performance, low power ARM compatible Sheeva™ CPU core operating at 800 MHz functions as a Service Processor and interfaces to a high speed DDRII-320MHz memory controller.

Board management devices include power controller, elapsed time recorder, temperature sensors, and real time clock.

Port Description

All Gigabit Ethernet ports support 10/100/1000 Mbps rates through 10Base-T/100Base-TX/1000Base-T connections.

Port Features

- Auto Negotiation Supported
- Auto MDI/MDIX Supported
- Head of Line (HOL) Blocking Prevention Supported
- Flow Control (IEEE 802.3X) Support
- Back Pressure Support
- Jumbo Frames Support
- Cable Analysis
- Manual Port Control and Identification Supported



Mirroring

- Port Mirroring Supported
- VLAN Mirroring Supported

MAC Address Support

- VLAN-Aware MAC-based Switching Supported
- MAC Address Aging Supported
- Up to 16K MAC Entries
- Static MAC Entries Supported

Extended L3 Features

- Dual IP Stack Support
- RIP v6 Support
- OSPF v3 Support
- Routing Table Management and Route Redistribution
- Route Maps Supported
- PIM Support

VLAN Support

- Up to 4094 VLANs Supported
- Predefined Default VLAN
- Protected Ports Supported
- Private VLAN Edge Supported
- GVRP & GARP Supported
- Protocol-based VLANs Supported
- Port-based VLANs Supported
- Subnet-based VLANs Supported
- MAC-based VLANs Supported
- Nested VLANs (QinQ) Supported
- Multicast VLAN Registration (MVR) Support
- Multicast TV VLAN Support
- Auto Voice VLAN Support

Multicast

- Static Multicast Groups (256 Groups Supported)
- IGMP Snooping Supported (IGMP v1, v2, & v3)
- MLD Snooping Supported (MLD v1 & v2)
- Unregistered Multicast Filtering Supported
- IGMP Querier Supported

Spanning Tree

- Per-device Spanning Tree (IEEE 802.1D)
- Rapid Spanning Tree – RSTP (IEEE 802.1W)
- Multiple Spanning Tree – MSTP (IEEE 802.1S)
- Spanning Tree Fast Link Option
- STP Root Guard Supported
- STP BPDU Guard Supported
- BPDU Flooding/Filtering Supported (when STP is disabled on the switch or on the port)
- Loopback Detection Supported

Link Aggregation

- Up to 8 LAGs Supported, each with up to 8 port members
- LACP Support
- LAG Balancing Algorithm Support

Access Control Lists

- Up to 2k ACLs Supported
- MAC ACL Condition Supported
- IP ACL Condition Supported
- Time-based ACL Supported

Supported ACL Actions

- Forward Packet
- Drop Packet
- Drop Packet and Disable Ingress Port

QoS/CoS and Rate Limiting

- QoS Basic Mode Supported
- QoS Advanced Mode Supported
- Trust Configuration in Basic Mode
- Port Based Priority Supported
- Queue Mapping for 8 and 4 Queue Devices
- QoS Policy Customization
- QoS Statistics
- Ingress Rate Limiting Accurate Mechanism
- Egress Rate Limiting (Shaping)
- Rate Limiting Action in ACL
- Packet Storm Control

System IP Address Management

- Static Assignment of up to 32 IP Addresses
- Management VLAN
- DNS Client
- IPv6 Host
- DHCP Server
- DHCP Relay Option 82

IP Routing

- Up to 128 Static Routes
- Up to 1024 ARP Entries
- Proxy ARP Supported
- L3 DHCP Relay Supported
- UDP Relay Supported
- RIP v2 Supported



Security

- MAC-based Port Security Supported
- IEEE 802.1X Support
- Guest VLAN Support
- Unauthenticated VLAN Support
- Dynamic VLAN Assignment Supported
- Dynamic ACL (DACL) for Ingress Supported
- Remote Authorization and Authentication (RADIUS) Support (8 servers)
- Radius Accounting Supported
- TACACS+ Support (8 servers)
- Local Authentication Support
- Authentication Method Configuration & Priority
- DHCP Snooping Supported
- IP Source Guard Supported
- Dynamic ARP Inspection Supported

Graphical Switch Management Interface

- Embedded Web Server provides HTML Pages for Switch Management from Web Browser Interface
- HTTP/HTTPS (SSL v3) Supported

CLI Switch Management

- Multi-Session Telnet Connections Supported
- SSH Connections Supported
- RS-232 Console Port Connection Supported

Management Features

- Inactivity Timer for Management Sessions
- Password Security Supported
- Cryptography Supported
- Certificate Expiration Support
- Event Logging Supported
- Multiple User Support
- Soft Reset Supported
- SNTP (Simple Network Time Protocol) Support
- Ping Facility Supported
- Traceroute Supported
- LLDP (IEEE 802.1AB) + LLDP MED Supported
- Switch Auditing Supported

Configuration Management

- Configuration File Handling
- Clearing and Deleting
- HTTP/S Down/Upload of Configuration Files
- Auto Configuration Backup

SNMP

- SNMP v1, v2c, and v3 Supported
- MIB File Support
- Other MIB Placing
- OID Placing

Monitoring

- CPU Utilization
- Port/Link Utilization
- TCAM Utilization
- RMON Support
- sFlow (flow monitoring) Support
- Power Supply Status
- Temperature Status

Rugged Enclosure

The enclosure of the A661 is built to be rugged and reliable as well as lightweight and compact. EMI/RFI protected and environmentally sealed, the chassis is capable of withstanding extreme environmental conditions of altitude, temperature, humidity, shock, vibration, EMI and chemical exposure, making it ideal for use in military environments.

Cooling of the A661 is by means of a cold plate. Heat from the cards in the enclosure is conducted to the aluminum sidewalls, and from there to the cold plate.

All mating surfaces of the chassis structure have electrically conductive seals to prevent penetration of moisture and dust, and to improve EMI/RFI characteristics. A grounding screw is provided on the front panel.

The enclosure backplane has two 6U CompactPCI slots for the two C660 boards and a power supply slot to accommodate the modular power supply.

Routing of I/O signals between the backplane and the front panel connectors is accomplished using Aitech's proprietary solid-state transition module rather than harnessing. Use of a transition module provides enhanced I/O signal integrity for the following two reasons and superior reliability.

Power to the system is provided by an Aitech modular high efficiency rugged power supply. An input power line filter integral to the I/O transition module reduces EMI/RFI noise to/from the power cable, and additional filtering is provided on the power supply board.

All system power and I/O connections are via rugged military grade MIL-STL-38999 connectors on the A661 front panel.



A661

2 x 24-Port Rugged Managed Ethernet Switch

Mechanical Features

Dimensions

Dimensions are in mm (in), and are rounded up to nearest mm/0.1 inch.

	W	D	H
Footprint	275 (10.9)	213 (8.4)	130 (5.2)
Envelope*	277 (10.9)	240 (9.5)	130 (5.2)

* includes front panel connectors and lifting handles.

Weight

Less than 7.5 kg

Thermal Management

The A661 is cooled by a 50 °C cold plate. No fan or other means of cooling are required.

Power Requirements

The A661 is powered by a standard 28 Vdc (nominal) power supply per MIL-STD-704D (with 16V minimum input voltage). It is protected by an input line filter to minimize EMI/RFI.

Maximum power consumption is less than 75W.

Environmental

The A661 will operate reliably when mounted on a 50 °C cold plate.

A661 Ordering Information

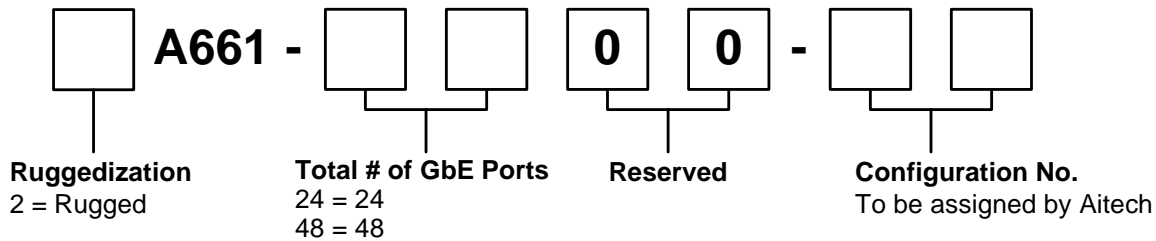

Example: 2A661-4800-00

For more information about the A661 or any Aitech product, please contact Aitech Defense Systems sales department at (888) Aitech-8 (248-3248).